

## ThermoFlexX 30



The ThermoFlexX 30 with its maximum plate size of 635 x 762 mm (25 x 30") is the perfect fit for the narrow and medium web segment. It's an excellent choice for ambitious label printers who want their own productive imager and to remain independent whilst making plates in the shortest possible time. ThermoFlexX 30 is an ideal size to fit easily into available space with realistic costs for plate processing equipment and digital workflow.

### High quality imaging

- + The new generation optical system offers superior quality thanks to a unique design using leading edge technology. The fiber laser represents today's best technology for digital imaging, offering superior quality. The robustly designed ThermoFlexX is made using heavy duty industrial components, making high speeds possible without fluctuation and vibrations. This provides the most accurate and consistent imaging quality available today.

### High Resolution

- + With 5080 dpi resolution, we push quality standards to a higher level.
- + smaller screen dots & finer details
- + sharper text and line-work
- + full image contrast
- + greater production stability through platemaking and printing

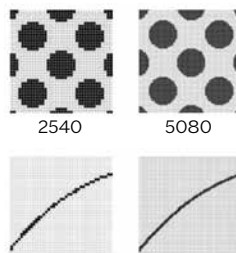

### Open

- + ThermoFlexX imagers excel in their choice of resolution. Any of the industry standards can be used. ThermoFlexX imagers can be integrated with any workflow or RIP that can produce 1-bit TIFF file format. Closed file formats such as LEN-files can be seamlessly converted to 1-bit TIFF. ThermoFlexX can image all digital plates, any brand, solvent, water washable or thermal processing, and is compatible with all plate making equipment.

### Multi Resolution

- + ThermoFlexX supports all 1-bit TIFF formats from any RIP at all standard resolutions 2400, 2540, 4000, 4800, 5080 and 10.160 dpi. Closed file formats such as LEN files can be converted seamlessly to 1-bit TIFF format. In the Multiplate software, TIFF's with different resolution can be combined on one plate.

### Vacuum Slider

- + Optimum plate handling and manipulation avoids accidental damage. The vacuum slider, a unique feature of ThermoFlexX imagers, offers efficient operation for partial plates. By moving the slider to the edge of the plate the vacuum is concentrated beneath the plate, which eliminates the need for taping and film covering and still allows full speed imaging.

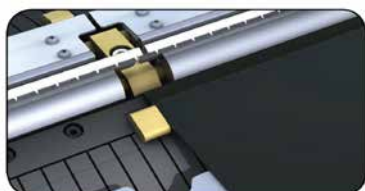

### Convenient clamping

- + Operated by a pedal, the clamping system allows for seamless plate loading. While opening the clamps the drum is automatically locked for efficient positioning of the plate. A choice of clamps is available according to your plate material.

### Multi Plate

- + MultiPlate is an intuitive interface providing amazing ease of use. 1-bit TIFF's are arranged automatically or manually and jobs of different resolutions can be combined. The status of different jobs is clearly presented. With the search and filter tool you can easily find files, even if they are stored in an archive.

# ThermoFlexX 30

Technical characteristics	ThermoFlexX 30.2	ThermoFlexX 30.3	ThermoFlexX 30.5
Laser type	Fiber laser 1064nm		
Laser power	20 W	35 W*	50 W*
Standard resolution <sup>1</sup>	2400 2540	2400 2540	2400 2540
High resolution <sup>1</sup>	4000* 4800*	4000* 4800*	4000* 4800*
10.160 dpi for Security printing	5080*	5080*	5080*
Productivity 2400dpi <sup>2</sup>	1	2*	3*
Productivity 5080dpi <sup>2</sup>	1	2*	2.25*
Image quality	at 2540 dpi: up to 175lpi / at 5080 dpi: up to 250lpi		
Loading table	Top loading table		
Hybrid Drum option	Optional		
Customized register pins	Optional		
Customized magnetic zones	Optional		
Clamping system	Operated by a foot pedal		
Resolution change	Automatically		
Focus setting	Auto focus		
Plate loading	Manual		
Partial Plate handling	Vacuum Slider		
Maximum Plate sizes (drum dimensions)	635 x 762mm or 25" x 30" (width: 635 mm / circumference: 762 mm)		
Plate thickness	0.73 to 3.94mm 0.029 to 0.155"		
Mountable plate materials	Flexo plates and letterpress plates on polyester base Dry Films 0,2mm Digital Screens Gallus Screeny  Optional: Metal back letterpress plates* Steel backed plates require hybrid drum option		
Applications	Label & Tag Folding Carton		
Top & Bottom clamp space	15mm / 0.6"		
Machine dimensions	Width: 1112mm / 44" Depth: 871 / 35" Height: 1434mm / 57"		
Required Floor Space	3000 x 3000 mm 118"x 118"		
Weight	300 kg/ 661 lb		
Compressed Air	Not required		
Electrical connection	Voltage: 1x230 V (+/-5%) N, PE Frequency: 50 Hz- 60 Hz power consumption: 2.3 kVA plug: CEE 7/4"Shuko" Fuse: 12A		
Exhaust & Filter system	Internal filter system provided		
Vacuum system	Internal vacuum system provided		
Operating conditions	Humidity, max 70% Temperature 15-26° / 59-79 F / (+/-2%)		
Multiplate Software Platform Specification	Windows 10 Professional Server 64 bit 3 Ghz Quad Core (4 cores with Hyperthreading) 16 GB RAM DVD ROM/ Minimum 1USB port for Dongle Dual 100/1000 Network Interface 1 TB hard disk		

<sup>1</sup>) By default one resolution (2400 or 2540dpi) comes with the imager. Additional resolutions are optional.

<sup>2</sup>) Depending on plate type and quality requirements. Thicker plates are imaged 60% of the mentioned productivity.

\* Optional

## Please contact us for additional information.

info@xsyglobal.com • www.xsyglobal.com • www.thermoflexx.com

The aim of our technical documents is to inform and advise our customers. The information provided herein is correct to the best of Flint Group's knowledge. No liability for any errors, facts or opinions is accepted. Customers must satisfy themselves as to the suitability of this product for their application. No responsibility for any loss as a result of any person placing reliance on any material contained herein will be accepted. Product names followed by ® are trademarks registered by Flint Group.

Front view

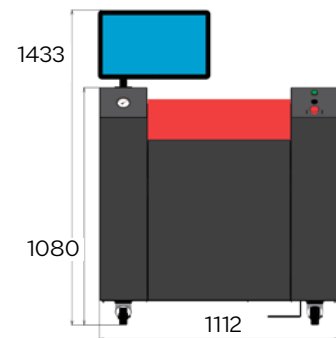

Side view



Plan view

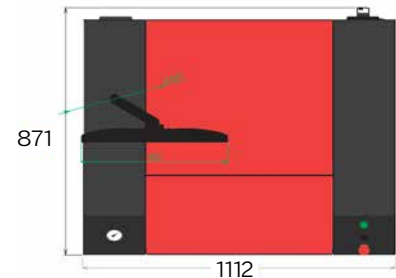

Floor plan

